



HCS8N65 N-CHANNEL MOSFET

FEATURES

- Low gate charge
- Low C_{rss} (typical 14pF)
- Fast switching
- 100% avalanche tested
- Improved dv/dt capability
- RoHS product

APPLICATIONS

- High efficiency switch mode power supplies
- Electronic lamp ballasts based on half bridge
- LED power supplies

主要参数 MAIN CHARACTERISTICS

I_D		8.0 A
V_{DSS}		650 V
R_{dson} ($V_{GS}=10V$)	Typ	1.05 Ω
	Max	1.35 Ω
Q_g -typ		32nC

产品特性

- 低栅极电荷
- 低 C_{rss} (典型值 14pF)
- 开关速度快
- 产品全部经过雪崩测试
- 高抗 dv/dt 能力
- RoHS 产品

用途

- 高频开关电源
- 电子镇流器
- LED 电源

封装 Package

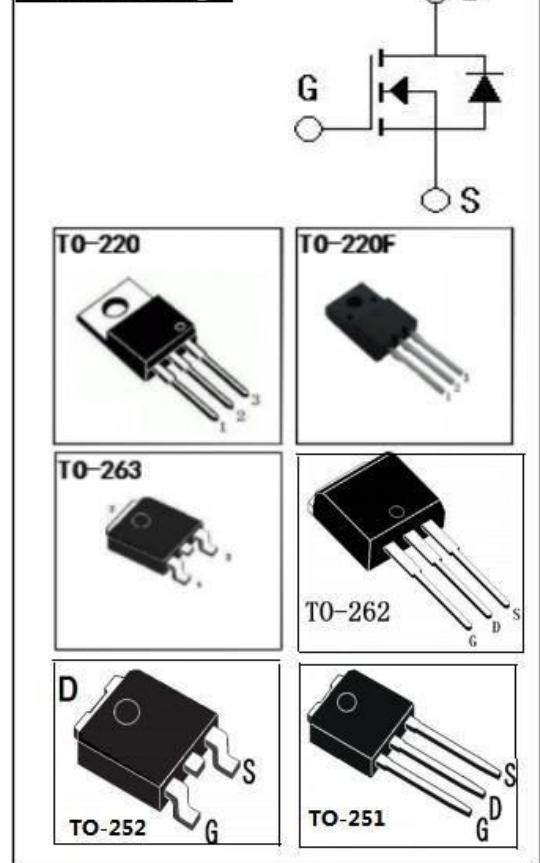

产品型号信息 PRODUCT MESSAGE

型号 Model	印记 Marking	封装 Package
HCS8N65C	HCS8N65C	TO-220
HCS8N65D	HCS8N65D	TO-220F
HCS8N65S	HCS8N65S	TO-263
HCS8N65B	HCS8N65B	TO-262
HCS8N65R	HCS8N65R	TO-252
HCS8N65V	HCS8N65V	TO-251



HCS8N65 N-CHANNEL MOSFET

绝对最大额定值 ABSOLUTE RATINGS (Tc=25°C)

项 目 Parameter	符 号 Symbol	数 值 Value			单 位 Unit
		TO-220/262/252/251	TO-220F		
最高漏极-源极直流电压 Drain-Source Voltage	V _{DSS}	650			V
连续漏极电流 Drain Current -continuous	I _D T=25°C	8.0			A
	T=100°C	4.6			A
最大脉冲漏极电流 (注 1) Drain Current - pulse (note 1)	I _{DM}	28	28*		A
最高栅源电压 Gate-Source Voltage	V _{GSS}	±30			V
单脉冲雪崩能量 (注 2) Single Pulsed Avalanche Energy (note 2)	E _{AS}	710			mJ
雪崩电流 (注 1) Avalanche Current (note 1)	I _{AR}	8.0			A
重复雪崩能量 (注 1) Repetitive Avalanche Current (note 1)	E _{AR}	12.6			mJ
二极管反向恢复最大电压变化速率 (注 3) Peak Diode Recovery dv/dt (note 3)	dv/dt	4.5			V/ns
耗散功率 Power Dissipation	P _D T _C =25°C	120	54.34		W
	Derate above 25°C	1.04	0.434		W/°C
最高结温及存储温度 Operating and Storage Temperature Range	T _J , T _{STG}	-55~+150			°C
引线最高焊接温度 Maximum Lead Temperature for Soldering Purposes	T _L	300			°C

*漏极电流由最高结温限制

*Drain current limited by maximum junction temperature



HCS8N65 N-CHANNEL MOSFET

电特性 ELECTRICAL CHARACTERISTICS

项 目 Parameter	符 号 Symbol	测试条件 Tests conditions	最小 Min	典型 Typ	最大 Max	单位 Units
关态特性 Off –Characteristics						
漏-源击穿电压 Drain-Source Voltage	BV_{DSS}	$I_D=250\mu A, V_{GS}=0V$	650	-	-	V
击穿电压温度特性 Breakdown Voltage Temperature Coefficient	$\Delta BV_{DSS}/\Delta T_J$	$I_D=250\mu A$, referenced to $25^\circ C$	-	0.64	-	V/ $^\circ C$
零栅压下漏极漏电流 Zero Gate Voltage Drain Current	I_{DSS}	$V_{DS}=650V, V_{GS}=0V,$ $T_C=25^\circ C$	-	-	10	μA
		$V_{DS}=520V, T_C=125^\circ C$	-	-	100	μA
正向栅极体漏电流 Gate-body leakage current, forward	I_{GSSF}	$V_{DS}=0V, V_{GS}=30V$	-	-	100	nA
反向栅极体漏电流 Gate-body leakage current, reverse	I_{GSSR}	$V_{DS}=0V, V_{GS}=-30V$	-	-	-100	nA
通态特性 On-Characteristics						
阈值电压 Gate Threshold Voltage	$V_{GS(th)}$	$V_{DS} = V_{GS}, I_D=250\mu A$	2.0	-	4.0	V
静态导通电阻 Static Drain-Source On-Resistance	$R_{DS(ON)}$	$V_{GS}=10V, I_D=3.5A$ $25^\circ C$		1.05	1.35	Ω
		$V_{GS}=10V, I_D=3.5A$ $100^\circ C$		1.84	2.35	Ω
		$V_{GS}=10V, I_D=3.5A$ $150^\circ C$	-	2.73	3.4	Ω
正向跨导 Forward Transconductance	g_{fs}	$V_{DS} = 40V, I_D=7.0A$ (note 4)	-	7.5	14	S
动态特性 Dynamic Characteristics						
栅极电阻 Gate resistance	R_g	$F=1.0MHz$ open drain	0.8	-	4.0	Ω
输入电容 Input capacitance	C_{iss}	$V_{DS}=25V,$ $V_{GS}=0V,$ $f=1.0MHz$		1100	1600	pF
输出电容 Output capacitance	C_{oss}			251	300	pF
反向传输电容 Reverse transfer capacitance	C_{rss}			14	20	pF



HCS8N65 N-CHANNEL MOSFET

电特性 ELECTRICAL CHARACTERISTICS

开关特性 Switching Characteristics

延迟时间 Turn-On delay time	$t_{d(on)}$	$V_{DD}=325V, I_D=7.0A, R_G=25\Omega$ (note 4, 5)	-	11	31	ns
上升时间 Turn-On rise time	t_r		-	35	80	ns
延迟时间 Turn-Off delay time	$t_{d(off)}$		-	46	95	ns
下降时间 Turn-Off Fall time	t_f		-	40	92	ns
栅极电荷总量 Total Gate Charge	Q_g	$V_{DS}=520V,$ $I_D=7.0A$ $V_{GS}=10V$ (note 4, 5)	-	32	41	nC
栅-源电荷 Gate-Source charge	Q_{gs}		-	6	15	nC
栅-漏电荷 Gate-Drain charge	Q_{gd}		-	15	40	nC

漏-源二极管特性及最大额定值 Drain-Source Diode Characteristics and Maximum Ratings

正向最大连续电流 Maximum Continuous Drain-Source Diode Forward Current		I_S	-	-	8	A
正向最大脉冲电流 Maximum Pulsed Drain-Source Diode Forward Current		I_{SM}	-	-	28	A
正向压降 Drain-Source Diode Forward Voltage	V_{SD}	$V_{GS}=0V,$ $I_S=7.0A$	-	-	1.4	V
反向恢复时间 Reverse recovery time	t_{rr}	$V_{GS}=0V, I_S=7.0A$ $di/dt=100A/\mu s$ (note 4)	-	345	900	ns
反向恢复电荷 Reverse recovery charge	Q_{rr}		-	3.2	8.0	μC

热特性 THERMAL CHARACTERISTIC

项 目 Parameter	符 号 Symbol	最大 Max			单 位 Unit
		TO-220/262/252/251	TO-220F		
结到管壳的热阻 Thermal Resistance, Junction to Case	$R_{th(j-c)}$	1.04	2.3		$^{\circ}C/W$
结到环境的热阻 Thermal Resistance, Junction to Ambient	$R_{th(j-A)}$	62.5	35.67		$^{\circ}C/W$

注释:

- 1: 脉冲宽度由最高结温限制
- 2: $L=27mH, I_{AS}=8.0A, V_{DD}=50V, R_G=25\Omega$, 起始结温 $T_J=25^{\circ}C$
- 3: $I_{SD} \leq 7.0A, di/dt \leq 300A/\mu s, V_{DD} \leq BV_{DSS}$, 起始结温 $T_J=25^{\circ}C$
- 4: 脉冲测试: 脉冲宽度 $\leq 300\mu s$, 占空比 $\leq 2\%$
- 5: 基本与工作温度无关

Notes:

- 1: Pulse width limited by maximum junction temperature
- 2: $L=27mH, I_{AS}=8.0A, V_{DD}=50V, R_G=25\Omega$, Starting $T_J=25^{\circ}C$
- 3: $I_{SD} \leq 7.0A, di/dt \leq 300A/\mu s, V_{DD} \leq BV_{DSS}$, Starting $T_J=25^{\circ}C$
- 4: Pulse Test: Pulse Width $\leq 300\mu s$, Duty Cycle $\leq 2\%$
- 5: Essentially independent of operating temperature



特征曲线 ELECTRICAL CHARACTERISTICS (curves)

On-Region Characteristics

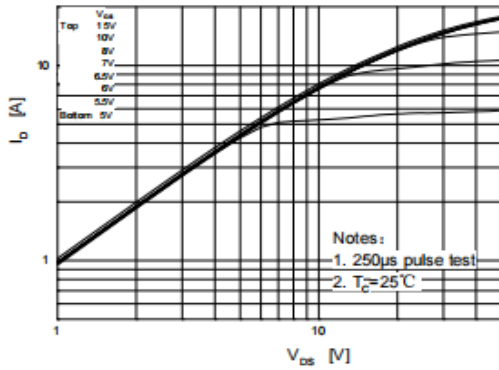

Transfer Characteristics

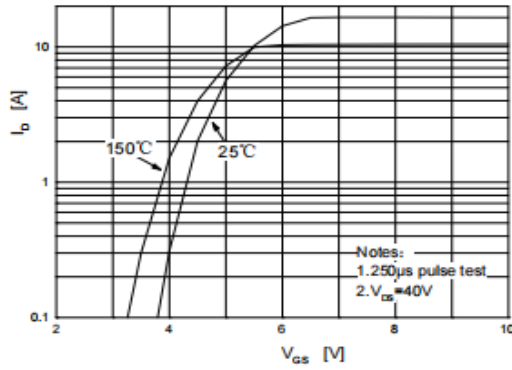

On-Resistance Variation vs. Drain Current and Gate Voltage

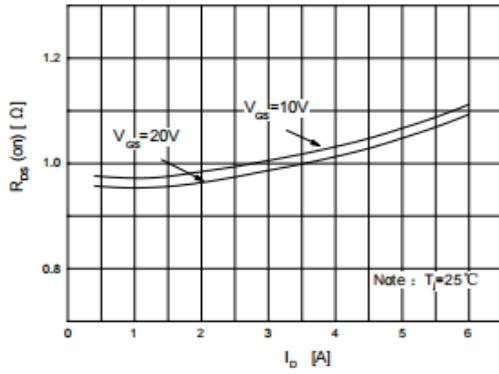

Body Diode Forward Voltage Variation vs. Source Current and Temperature

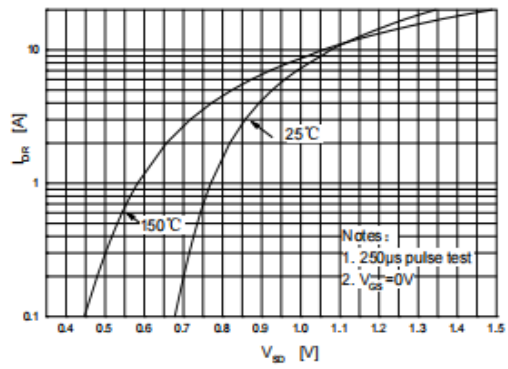

Capacitance Characteristics

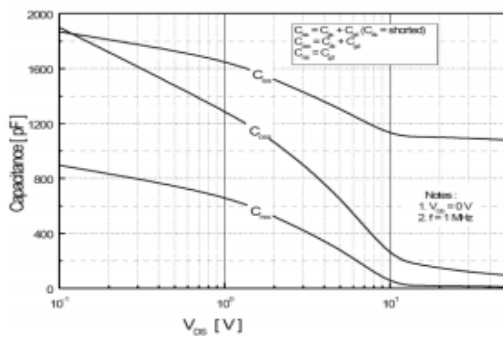

Gate Charge Characteristics

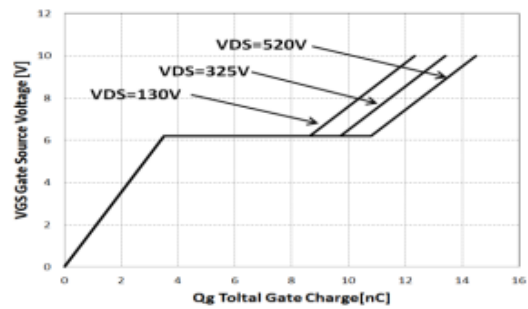



特征曲线 ELECTRICAL CHARACTERISTICS (curves)

Breakdown Voltage Variation vs. Temperature

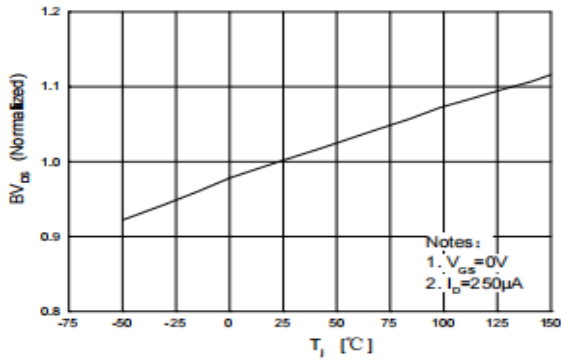

On-Resistance Variation vs. Temperature

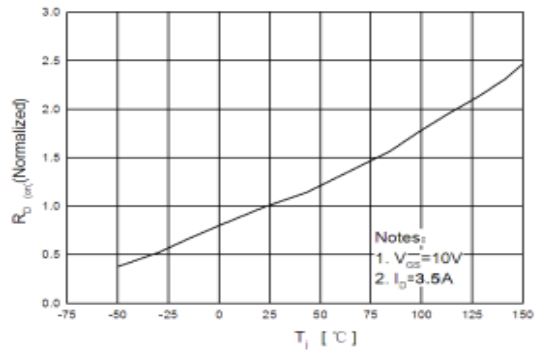

Maximum Safe Operating Area For TO-220/262/252/251

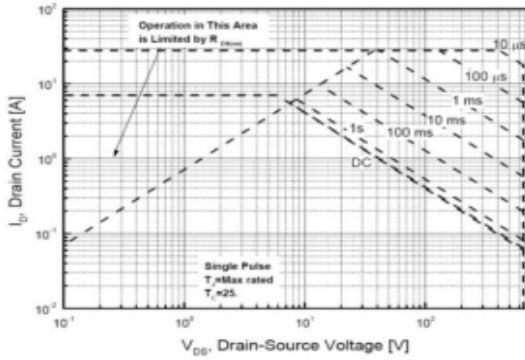



特征曲线 ELECTRICAL CHARACTERISTICS (curves)

特征曲线 ELECTRICAL CHARACTERISTICS (curves)

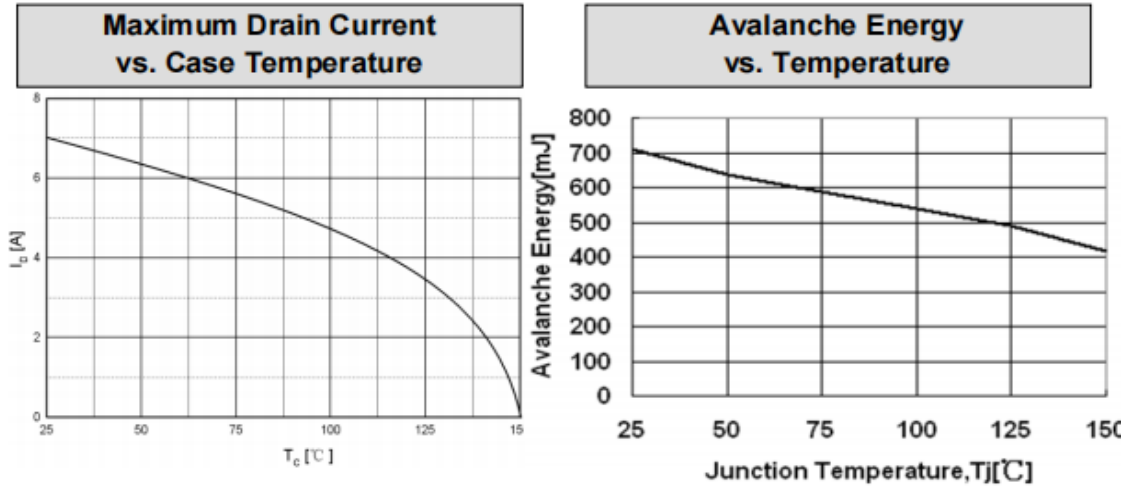

Transient Thermal Response Curve

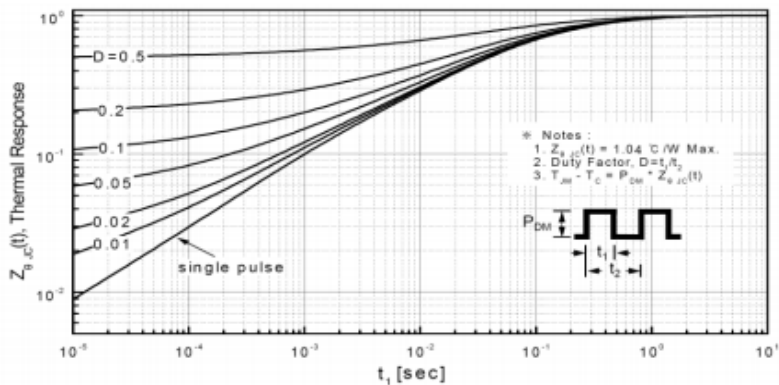



HCS8N65 N-CHANNEL MOSFET

外形尺寸 PACKAGE MECHANICAL DATA

TO-220

单位 Unit : mm

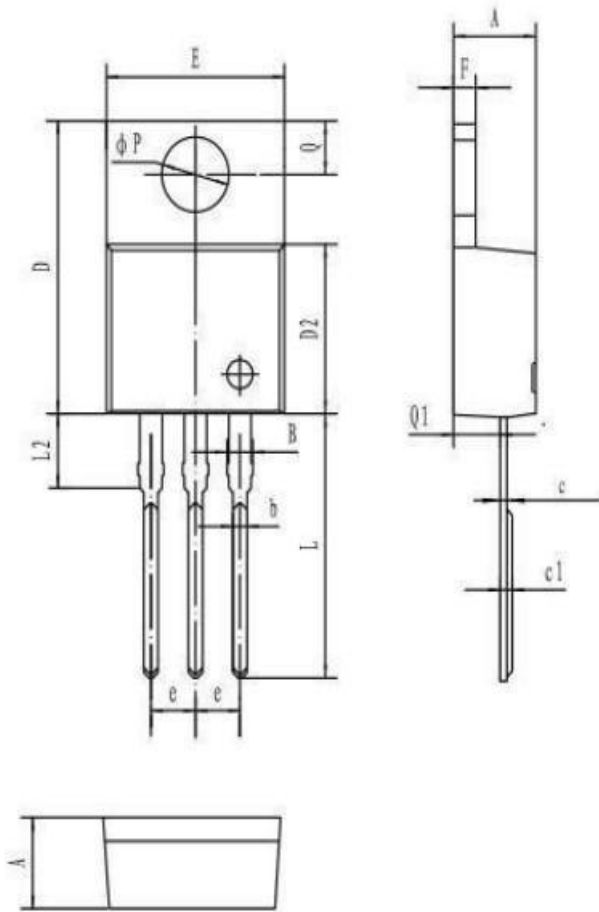

符号 symbol	MIN	MAX
A	4.40	4.80
B	1.10	1.40
b	0.70	0.95
c	0.28	0.48
c1	0.32	0.52
D	14.45	16.00
D2	8.20	9.20
E	9.60	10.40
e	2.39	2.69
F	1.20	1.35
L	13.05	14.05
L2	3.70	3.90
Q	2.40	3.00
Q1	2.20	2.90
P	3.50	4.00



HCS8N65 N-CHANNEL MOSFET

外形 寸 PACKAGE MECHANICAL DATA

TO-220F

单位 Unit : mm

Package Dimension

TO-220F

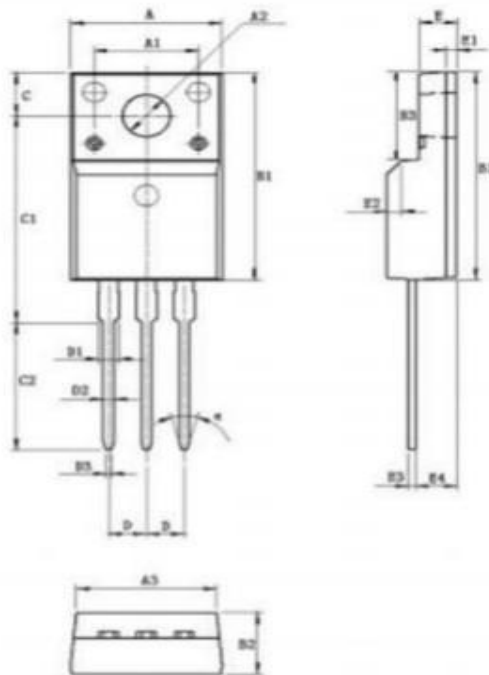

单位: mm

Symbol	Min	Max	Symbol	Min	Max
A	9.96	10.36	D	2.54	
A1	7.00		D1	1.15	1.35
A2	3.08	3.28	D2	0.70	0.90
A3	9.25	9.65	D3	0.28	0.48
B1	15.70	16.10	E	2.34	2.74
B2	4.50	4.90	E1	0.70	
B3	6.20	6.80	E2	1.0×45°	
C	3.20	3.40	E3	0.36	0.65
C1	15.20	16.00	E4	2.55	2.95
C2	9.75	10.15	a(度)	30°	



HCS8N65 N-CHANNEL MOSFET

外形尺寸 PACKAGE MECHANICAL DATA

TO-263

单位 Unit : mm

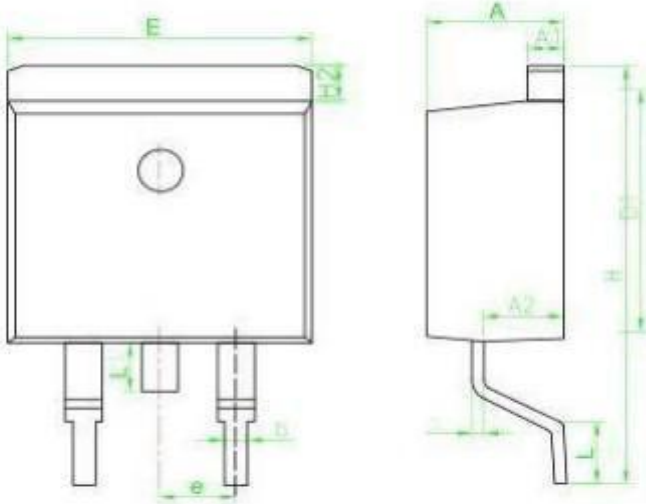

SYMBOL	MM	
	MIN	MAX
A	4.30	4.80
A1	1.12	1.42
A2	2.54	2.84
b	0.67	1.00
c	0.29	0.52
D1	8.40	9.00
E	9.80	10.46
e	2.54BSC	
H	14.00	16.00
H2	1.12	1.45
L	1.50	3.10
L1	1.45	1.70

编带 REEL

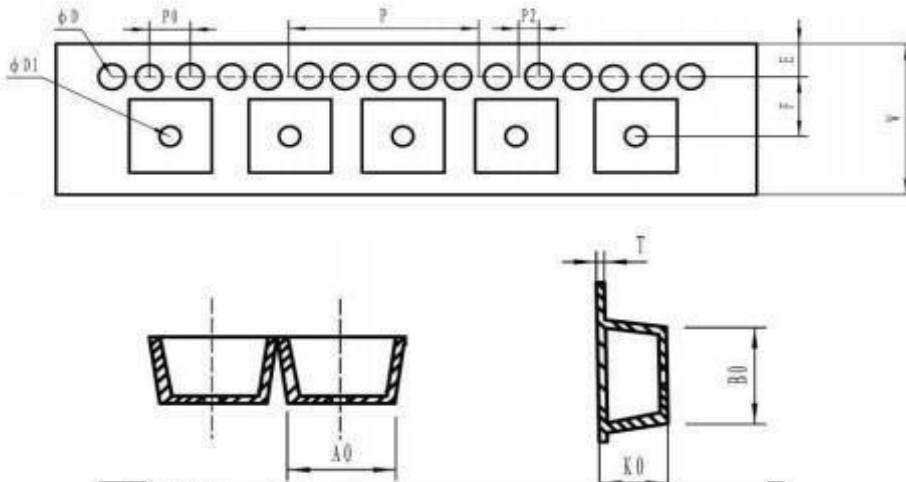

产品尺寸规格 (UNIT: mm)				
规格	V	A0	P	D
尺寸	24 ± 0.3	18.9 ± 0.2	1.75 ± 0.2	11.5 ± 0.2
规格	D1	P0	P2	T
尺寸	1.5 ± 0.2 / -0.1	4 ± 0.2	2 ± 0.2	0.35 ± 0.05
规格	K0	B0		
尺寸	4.9 ± 0.2	16.0 ± 0.2		



HCS8N65 N-CHANNEL MOSFET

外形尺寸 PACKAGE MECHANICAL DATA

TO-262

单位 Unit: mm

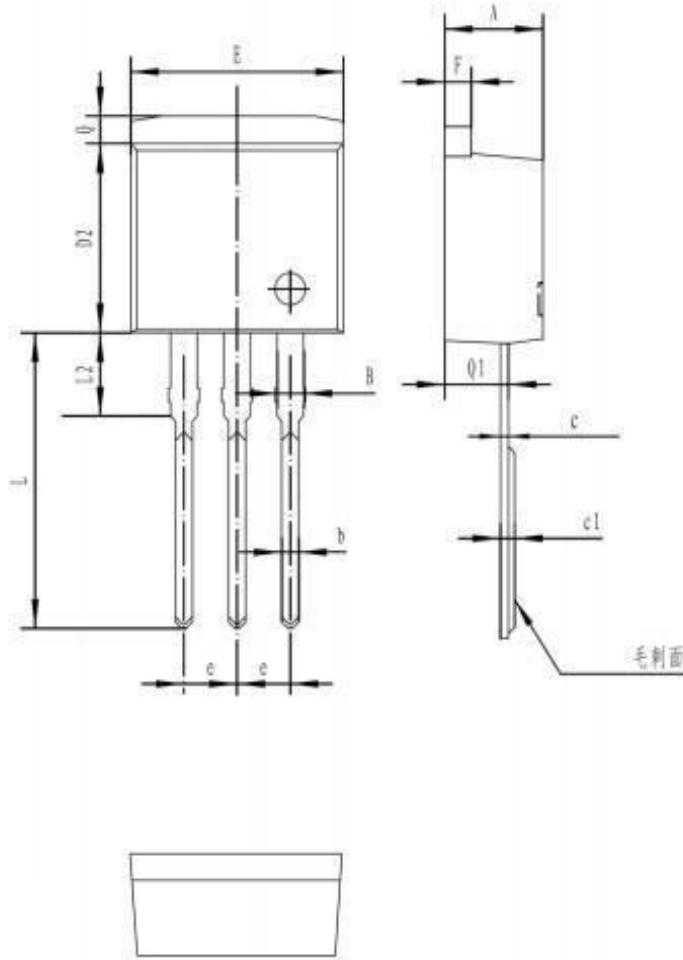

符号 symbol	MIN	MAX
A	4.40	4.90
B	1.10	1.40
b	0.70	0.95
c	0.30	0.60
c1	0.33	0.63
D2	8.20	9.20
E	9.60	10.50
e	2.39	2.69
F	1.20	1.35
L	13.11	14.61
L2	3.55	4.05
Q	1.10	1.40
Q1	2.65	2.85



HCS8N65 N-CHANNEL MOSFET

外形尺寸 PACKAGE MECHANICAL DATA

TO-252

单位 Unit : mm

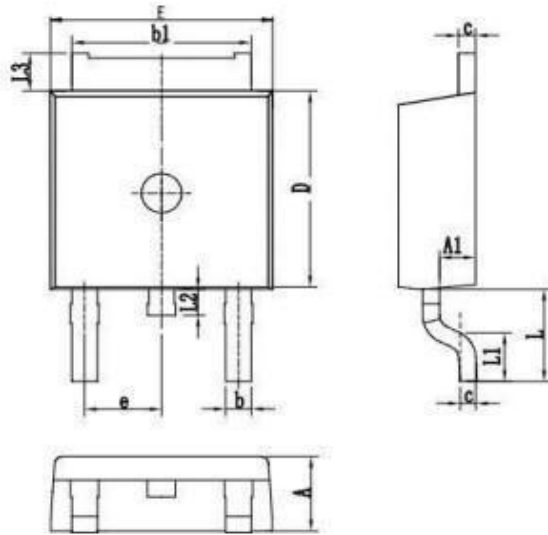

SYMBOL	mm	
	MIN	MAX
A	2.10	2.50
A1	0.80	1.20
b	0.66	0.96
b1	5.10	5.50
c	0.40	0.62
D	5.85	6.45
E	6.30	6.90
e	2.286BSC	
L	2.40	3.00
L1	0.85	1.45
L2	0.60	1.10
L3	0.67	1.07

编带 REEL

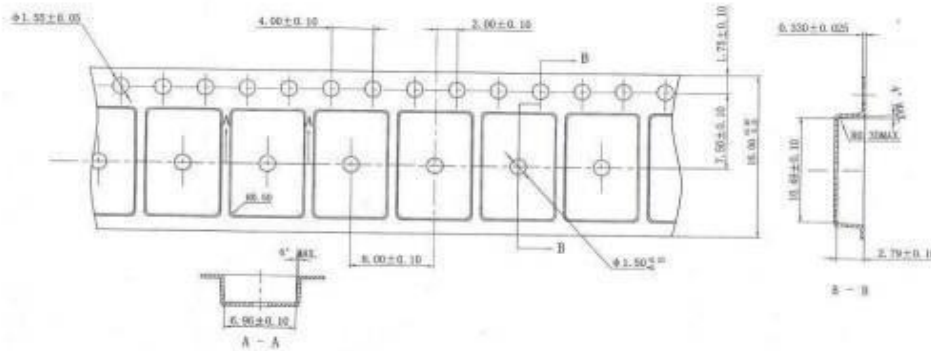



外形尺寸 PACKAGE MECHANICAL DATA TO-251

单位 Unit : mm

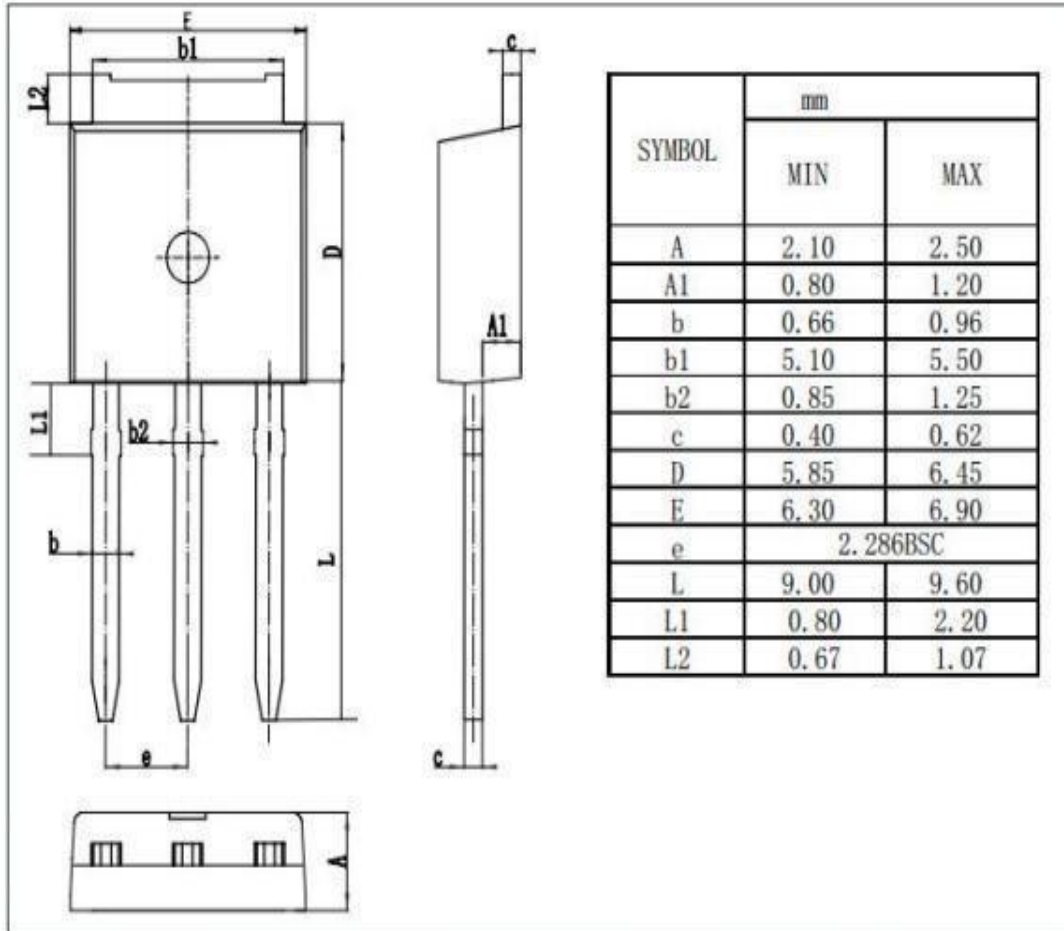



注意事项

1. 深圳市华天微电子有限公司的产品销售分为直销和销售代理，无论哪种方式，订货时请与公司核实。
2. 购买时请认清公司商标，如有疑问请与公司本部联系。
3. 在电路设计时请不要超过器件的绝对最大额定值，否则会影响整机的可靠性。
4. 本说明书如有版本变更不另外告知

NOTE

1. Shenzhen Huatianwei Electronics co., Ltd sales its product either through direct sales or sales agent , thus, for customers, when ordering , please check with our company.
2. We strongly recommend customers check carefully on the trademark when buying our product, if there is any question, please don't be hesitate to contact us.
3. Please do not exceed the absolute maximum ratings of the device when circuit designing.
4. Shenzhen Huatianwei Electronics co., Ltd reserves the right to make changes in this specification sheet and is subject to change without prior notice.

联系方式

深圳市华天微电子有限公司

公司地址：广东省深圳市龙华清湖硅谷动力清湖园A14栋3楼

电话：86-755-82047720

网址：www.htwdz.com.cn

邮箱：grf@htwdz.com.cn

CONTACT

SHENZHEN HUATIANWEI ELECTRONICS CO., LTD.

ADD: Floor 3, Building A14, Qinghu Power park, Qinghu Silicon Valley, Longhua, Shenzhen, China

TEL: 86-755-82047720

Web Site: www.htwdz.com.cn

邮箱：grf@htwdz.com.cn