



# HCS4N80 N-CHANNEL MOSFET

## FEATURES

- Low gate charge
- Low  $C_{rss}$  (typical 14pF)
- Fast switching
- 100% avalanche tested
- Improved dv/dt capability
- RoHS product

## APPLICATIONS

- High efficiency switch mode power supplies
- Electronic lamp ballasts based on half bridge
- UPS

## 主要参数 MAIN CHARACTERISTICS

$I_D$		4.0 A
$V_{DSS}$		800 V
$R_{dson}$ ( $V_{gs}=10V$ )	Typ	
	Max	2.8 $\Omega$
$Q_g$ -typ		16nC

## 产品特性

- 低栅极电荷
- 低  $C_{rss}$  (典型值 14pF)
- 开关速度快
- 产品全部经过雪崩测试
- 高抗 dv/dt 能力
- RoHS 产品

## 用途

- 高频开关电源
- 电子镇流器
- UPS 电源

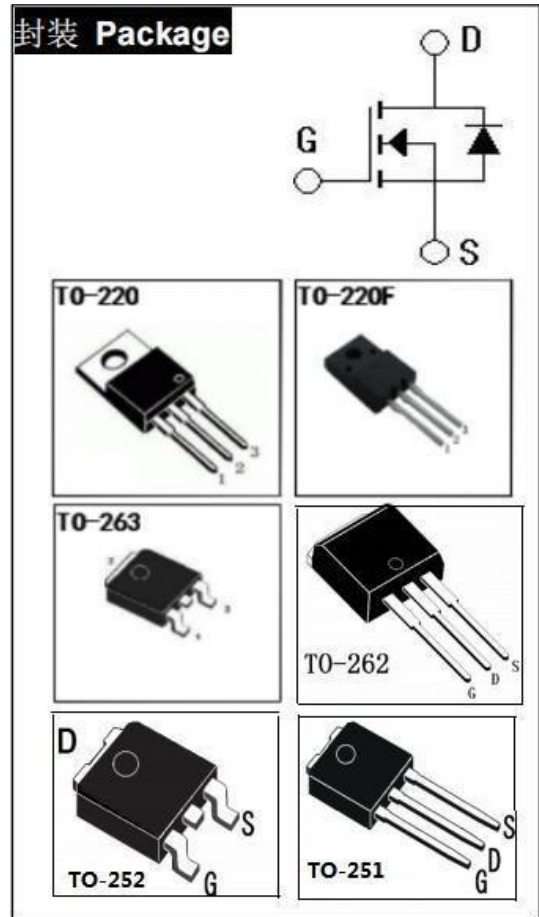

## 产品型号信息 PRODUCT MESSAGE

型号 Model	印记 Marking	封装 Package
HCS4N80C	HCS4N80C	TO-220
HCS4N80D	HCS4N80D	TO-220F
HCS4N80S	HCS4N80S	TO-263
HCS4N80B	HCS4N80B	TO-262
HCS4N80R	HCS4N80R	TO-252
HCS4N80V	HCS4N80V	TO-251



# HCS4N80 N-CHANNEL MOSFET

## 绝对最大额定值 ABSOLUTE RATINGS (Tc=25°C)

项 目 Parameter	符 号 Symbol	数 值 Value				单 位 Unit
		TO-252/251	TO-220/ 262	TO-220F		
最高漏极-源极直流电压 Drain-Source Voltage	V <sub>DSS</sub>	800				V
连续漏极电流 Drain Current -continuous	I <sub>D</sub> T=25°C	4.0				A
	T=100°C	2.5				A
最大脉冲漏极电流 (注 1) Drain Current - pulse (note 1)	I <sub>DM</sub>	16		16*		A
最高栅源电压 Gate-Source Voltage	V <sub>GSS</sub>	±30				V
单脉冲雪崩能量 (注 2) Single Pulsed Avalanche Energy (note 2)	E <sub>AS</sub>	265				mJ
雪崩电流 (注 1) Avalanche Current (note 1)	I <sub>AR</sub>	4.0				A
重复雪崩能量 (注 1) Repetitive Avalanche Current (note 1)	E <sub>AR</sub>	11.0				mJ
二极管反向恢复最大电压变化 速率 (注 3) Peak Diode Recovery dv/dt (note 3)	dv/dt	5.0				V/ns
耗散功率 Power Dissipation	P <sub>D</sub> T <sub>C</sub> =25°C	51	100			W
	Derate above 25°C	0.39	0.8			W/°C
最高结温及存储温度 Operating and Storage Temperature Range	T <sub>J</sub> , T <sub>STG</sub>	-55~+150				°C
引线最高焊接温度 Maximum Lead Temperature for Soldering Purposes	T <sub>L</sub>	300				°C

\*漏极电流由最高结温限制

\*Drain current limited by maximum junction temperature



## 电特性 ELECTRICAL CHARACTERISTICS

项 目 Parameter	符 号 Symbol	测试条件 Tests conditions	最小 Min	典型 Typ	最大 Max	单位 Units
<b>关态特性 Off –Characteristics</b>						
漏-源击穿电压 Drain-Source Voltage	$BV_{DSS}$	$I_D=250\mu A, V_{GS}=0V$	800	-	-	V
击穿电压温度特性 Breakdown Voltage Temperature Coefficient	$\Delta BV_{DSS}/\Delta T_J$	$I_D=250\mu A$ , referenced to $25^\circ C$	-	0.66	-	V/ $^\circ C$
零栅压下漏极漏电流 Zero Gate Voltage Drain Current	$I_{DSS}$	$V_{DS}=800V, V_{GS}=0V$ $T_C=25^\circ C$	-	-	10	$\mu A$
		$V_{DS}=560V, T_C=125^\circ C$	-	-	100	$\mu A$
正向栅极体漏电流 Gate-body leakage current, forward	$I_{GSSF}$	$V_{DS}=0V, V_{GS}=30V$	-	-	100	nA
反向栅极体漏电流 Gate-body leakage current, reverse	$I_{GSSR}$	$V_{DS}=0V, V_{GS}=-30V$	-	-	-100	nA
<b>通态特性 On-Characteristics</b>						
阈值电压 Gate Threshold Voltage	$V_{GS(th)}$	$V_{DS} = V_{GS}, I_D=250\mu A$	2.0	-	4.0	V
静态导通电阻 Static Drain-Source On-Resistance	$R_{DS(ON)}$	$V_{GS}=10V, I_D=2.0A$ $25^\circ C$	-	2.6	2.8	$\Omega$
			-			
			-			
正向跨导 Forward Transconductance	$g_{fs}$	$V_{DS} = 40V, I_D=2.0A$ (note 4)	-	3.6	-	S
<b>动态特性 Dynamic Characteristics</b>						
栅极电阻 Gate resistance	$R_g$	$F=1.0MHz$ open drain	0.8	-	5.5	$\Omega$
输入电容 Input capacitance	$C_{iss}$	$V_{DS}=25V, V_{GS}=0V, f=1.0MHz$	-	790	950	pF
输出电容 Output capacitance	$C_{oss}$		-	67	92	pF
反向传输电容 Reverse transfer capacitance	$C_{rss}$		-	14	17	pF

**电特性 ELECTRICAL CHARACTERISTICS**

开关特性 Switching Characteristics						
延迟时间 Turn-On delay time	$t_d(\text{on})$	$V_{DD}=350V, I_D=4.0A, R_G=25\Omega$ (note 4, 5)	-	30	50	ns
上升时间 Turn-On rise time	$t_r$		-	65	110	ns
延迟时间 Turn-Off delay time	$t_d(\text{off})$		-	50	130	ns
下降时间 Turn-Off Fall time	$t_f$		-	45	90	ns
栅极电荷总量 Total Gate Charge	$Q_g$	$V_{DS}=560V$ $I_D=4.0A$ $V_{GS}=10V$ (note 4, 5)	-	16	20	nC
栅-源电荷 Gate-Source charge	$Q_{gs}$		-	2.0		nC
栅-漏电荷 Gate-Drain charge	$Q_{gd}$		-	7.0		nC
漏-源二极管特性及最大额定值 Drain-Source Diode Characteristics and Maximum Ratings						
正向最大连续电流 Maximum Continuous Drain -Source Diode Forward Current		$I_S$	-	-	4	A
正向最大脉冲电流 Maximum Pulsed Drain-Source Diode Forward Current		$I_{SM}$	-	-	16	A
正向压降 Drain-Source Diode Forward Voltage	$V_{SD}$	$V_{GS}=0V, I_S=4.0A$	-	-	1.4	V
反向恢复时间 Reverse recovery time	$t_{rr}$	$V_{GS}=0V, I_S=4.0A$ $di_F/dt=100A/\mu s$ (note 4)	-	340		ns
反向恢复电荷 Reverse recovery charge	$Q_{rr}$		-	2.65		$\mu C$

**热特性 THERMAL CHARACTERISTIC**

项 目 Parameter	符 号 Symbol	最大 Max				单 位 Unit
		TO-252/251	TO-220/262			
结到管壳的热阻 Thermal Resistance, Junction to Case	$R_{th(j-c)}$	2.5	1.25			$^{\circ}C/W$
结到环境的热阻 Thermal Resistance, Junction to Ambient	$R_{th(j-A)}$	83	62.5			$^{\circ}C/W$

注释:

- 1: 脉冲宽度由最高结温限制
- 2:  $L=48mH, I_{AS}=4.0A, V_{DD}=50V, R_G=25\Omega$ , 起始结温  $T_J=25^{\circ}C$
- 3:  $I_{SD} \leq 4.0A, di/dt \leq 200A/\mu s, V_{DD} \leq BV_{DSS}$ , 起始结温  $T_J=25^{\circ}C$
- 4: 脉冲测试: 脉冲宽度  $\leq 300\mu s$ , 占空比  $\leq 2\%$
- 5: 基本与工作温度无关

Notes:

- 1: Pulse width limited by maximum junction temperature
- 2:  $L=48mH, I_{AS}=4.0A, V_{DD}=50V, R_G=25\Omega$ , Starting  $T_J=25^{\circ}C$
- 3:  $I_{SD} \leq 4.0A, di/dt \leq 200A/\mu s, V_{DD} \leq BV_{DSS}$ , Starting  $T_J=25^{\circ}C$
- 4: Pulse Test: Pulse Width  $\leq 300\mu s$ , Duty Cycle  $\leq 2\%$
- 5: Essentially independent of operating temperature



## 特征曲线 ELECTRICAL CHARACTERISTICS (curves)

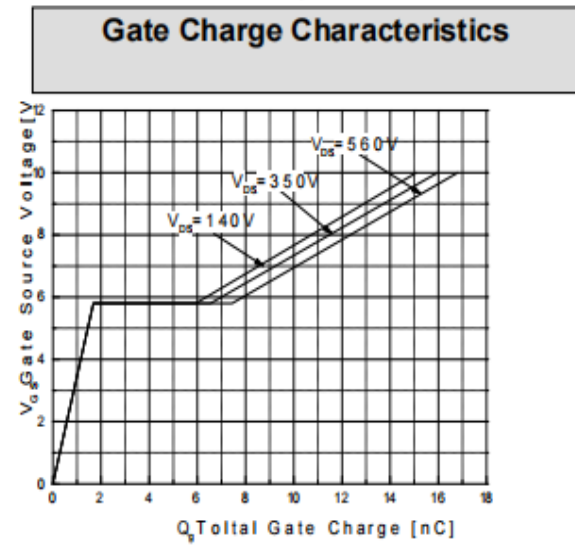
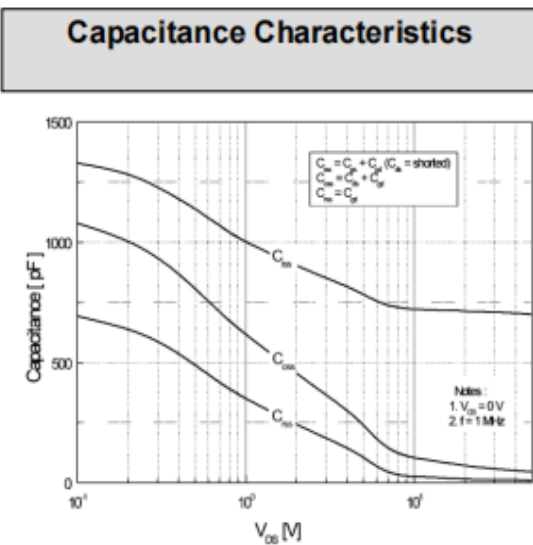
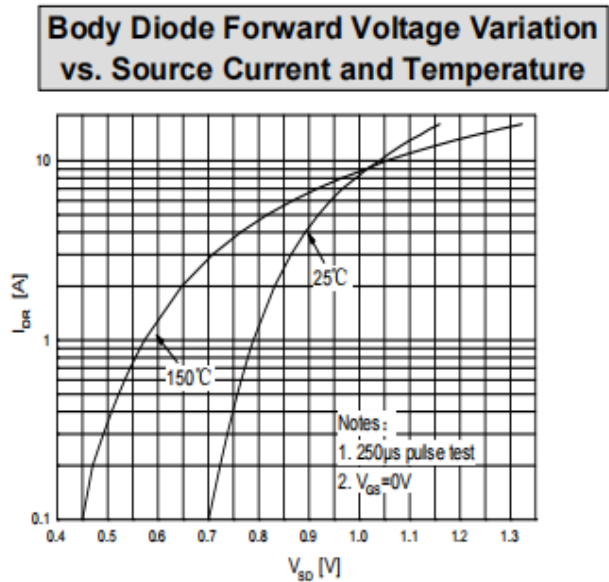
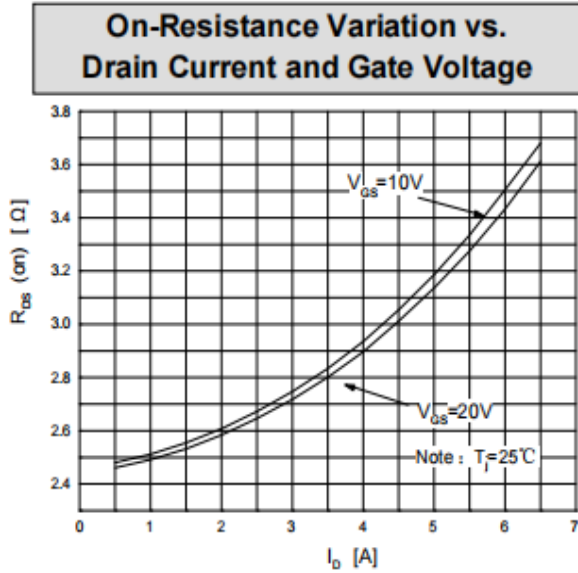
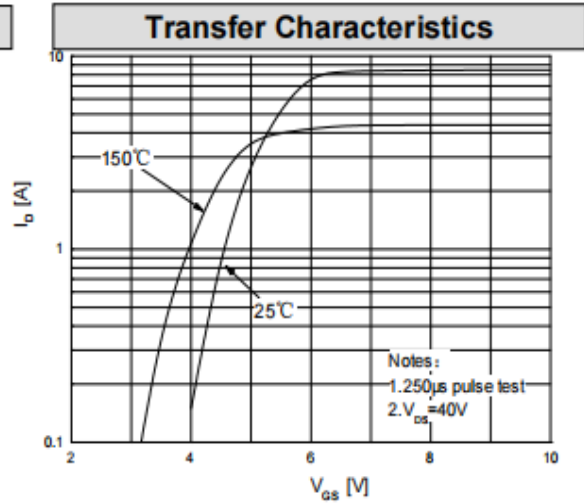
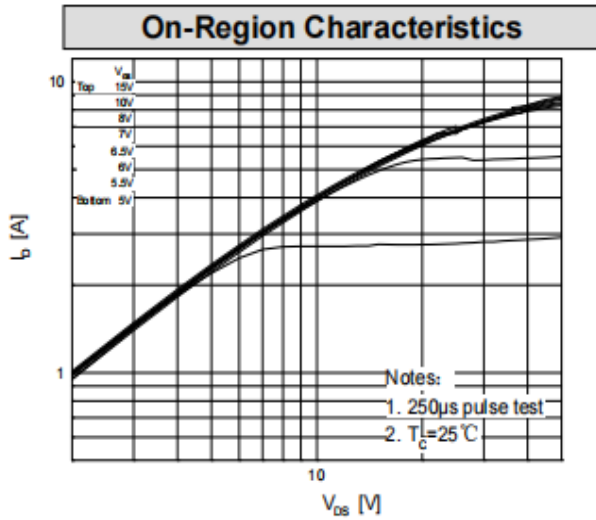



## 特征曲线 ELECTRICAL CHARACTERISTICS (curves)

### Breakdown Voltage Variation vs. Temperature

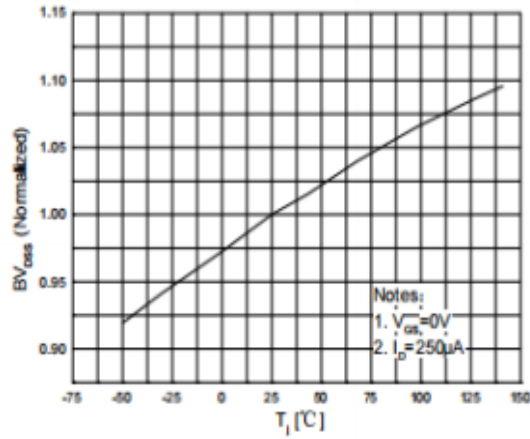

### On-Resistance Variation vs. Temperature

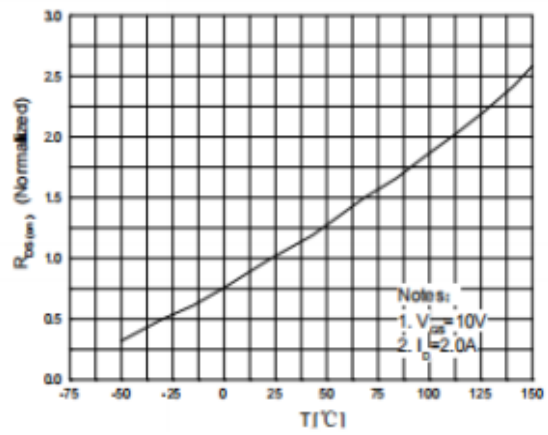

### Maximum Drain Current vs. Case Temperature

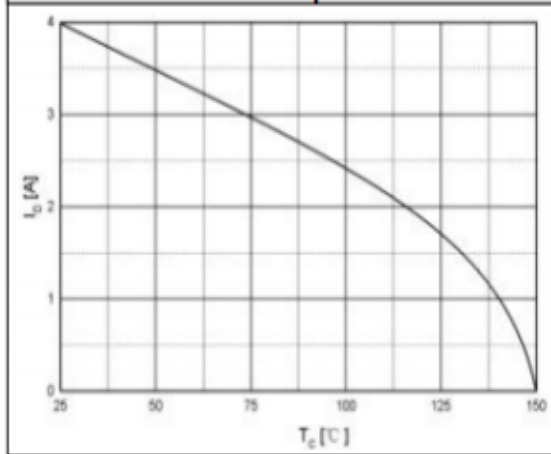

### Maximum Safe Operating Area For TO-220/262/252/251

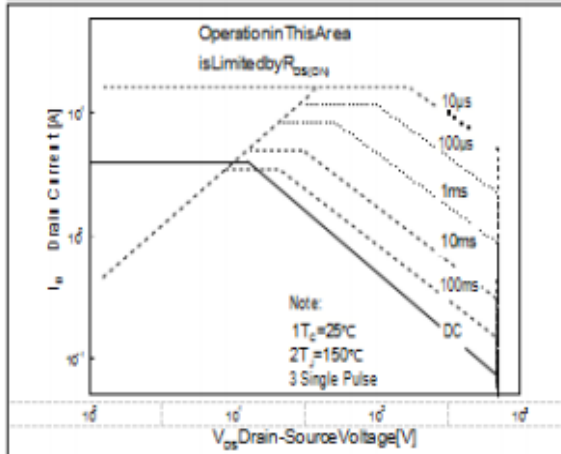



特征曲线 ELECTRICAL CHARACTERISTICS (curves)

Transient Thermal Response Curve For TO-252/251

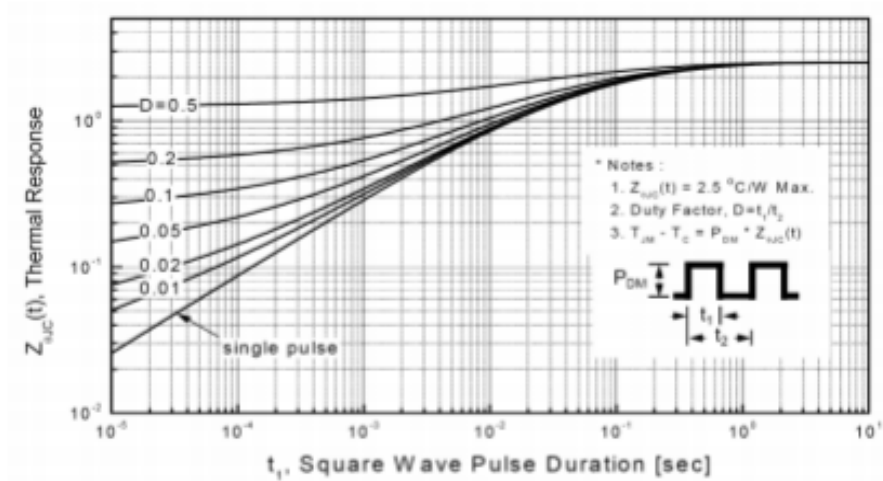

Transient Thermal Response Curve For TO-220/262

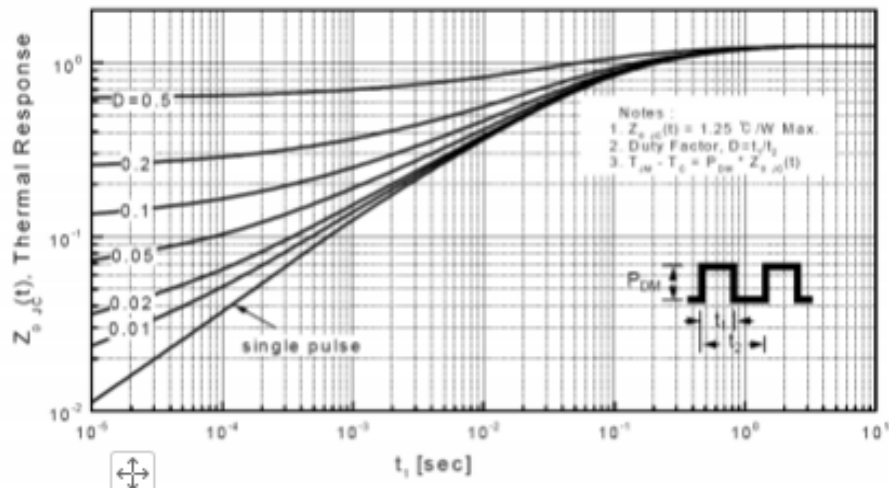



# HCS4N80 N-CHANNEL MOSFET

## 外形尺寸 PACKAGE MECHANICAL DATA

**TO-220**

单位 Unit : mm

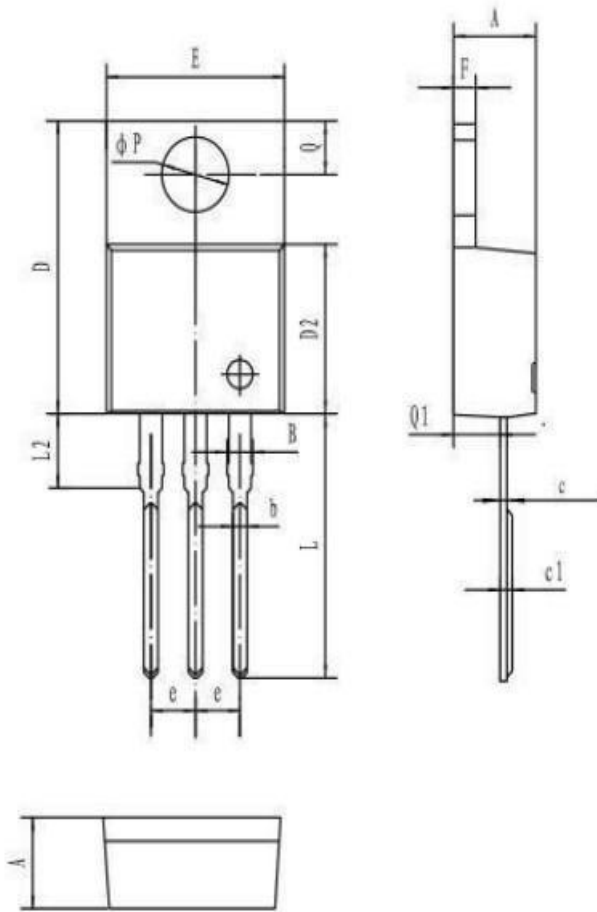

符号 symbol	MIN	MAX
A	4.40	4.80
B	1.10	1.40
b	0.70	0.95
c	0.28	0.48
c1	0.32	0.52
D	14.45	16.00
D2	8.20	9.20
E	9.60	10.40
e	2.39	2.69
F	1.20	1.35
L	13.05	14.05
L2	3.70	3.90
Q	2.40	3.00
Q1	2.20	2.90
P	3.50	4.00





### TO-220F

单位 Unit : mm

#### Package Dimension

#### TO-220F

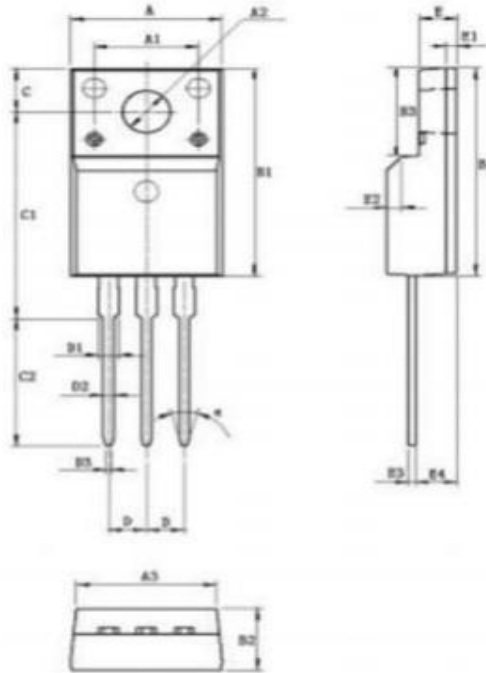

单位: mm

Symbol	Min	Max	Symbol	Min	Max
<b>A</b>	9.96	10.36	<b>D</b>	2.54	
<b>A1</b>	7.00		<b>D1</b>	1.15	1.35
<b>A2</b>	3.08	3.28	<b>D2</b>	0.70	0.90
<b>A3</b>	9.25	9.65	<b>D3</b>	0.28	0.48
<b>B1</b>	15.70	16.10	<b>E</b>	2.34	2.74
<b>B2</b>	4.50	4.90	<b>E1</b>	0.70	
<b>B3</b>	6.20	6.80	<b>E2</b>	1.0×45°	
<b>C</b>	3.20	3.40	<b>E3</b>	0.36	0.65
<b>C1</b>	15.20	16.00	<b>E4</b>	2.55	2.95
<b>C2</b>	9.75	10.15	a(度)	30°	



# HCS4N80 N-CHANNEL MOSFET

## 外形尺寸 PACKAGE MECHANICAL DATA

**TO-263**

单位 Unit : mm

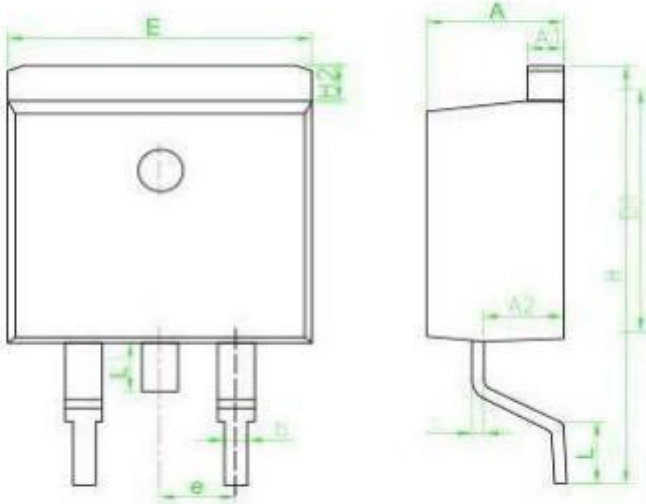

SYMBOL	MM	
	MIN	MAX
A	4.30	4.80
A1	1.12	1.42
A2	2.54	2.84
b	0.67	1.00
c	0.29	0.52
D1	8.40	9.00
E	9.80	10.46
e	2.54BSC	
H	14.00	16.00
H2	1.12	1.45
L	1.50	3.10
L1	1.45	1.70

### 编带 REEL

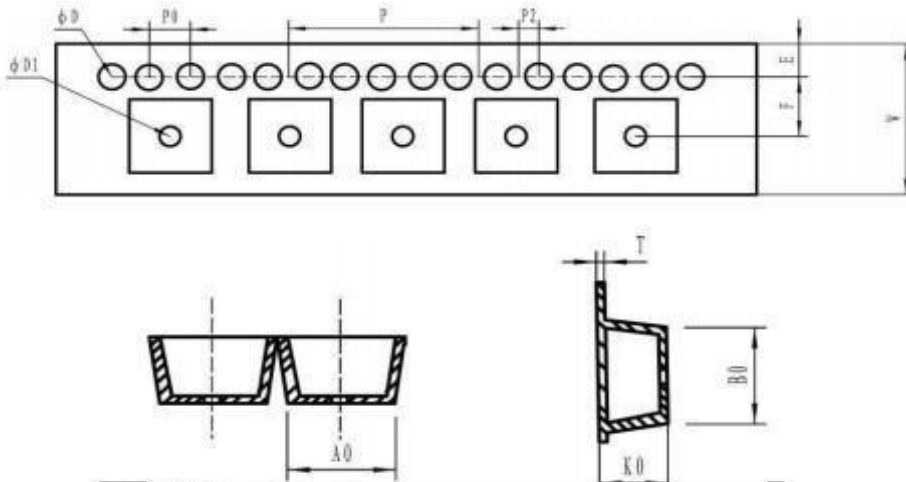

产品尺寸规格 (UNIT: mm)				
规格	W	A0	P	D
尺寸	24 ± 0.3	18.9 ± 0.2	1.75 ± 0.2	1.5 ± 0.2 / -0.1
规格	D1	P0	P2	T
尺寸	1.5 ± 0.2 / -0.1	4 ± 0.2	2 ± 0.2	0.35 ± 0.05
规格	K0	B0		
尺寸	4.9 ± 0.2	16.0 ± 0.2		



# HCS4N80 N-CHANNEL MOSFET

## 外形尺寸 PACKAGE MECHANICAL DATA

TO-262

单位 Unit: mm

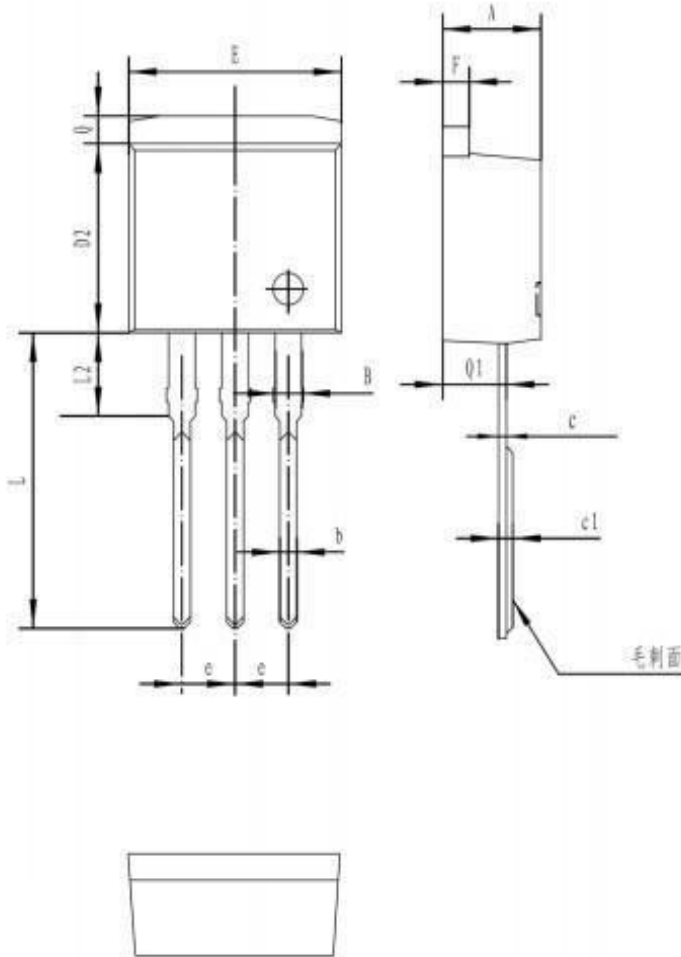

符号 symbol	MIN	MAX
A	4.40	4.90
B	1.10	1.40
b	0.70	0.95
c	0.30	0.60
c1	0.33	0.63
D2	8.20	9.20
E	9.60	10.50
e	2.39	2.69
F	1.20	1.35
L	13.11	14.61
L2	3.55	4.05
Q	1.10	1.40
Q1	2.65	2.85



# HCS4N80 N-CHANNEL MOSFET

## 外形尺寸 PACKAGE MECHANICAL DATA

**TO-252**

单位 Unit : mm

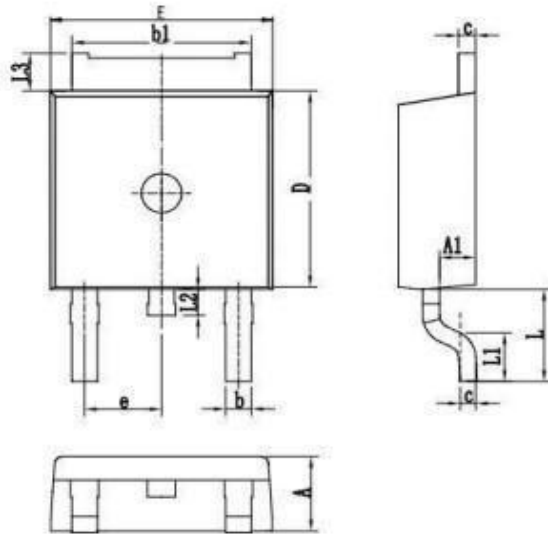

SYMBOL	mm	
	MIN	MAX
A	2.10	2.50
A1	0.80	1.20
b	0.66	0.96
b1	5.10	5.50
c	0.40	0.62
D	5.85	6.45
E	6.30	6.90
e	2.286BSC	
L	2.40	3.00
L1	0.85	1.45
L2	0.60	1.10
L3	0.67	1.07

### 编带 REEL

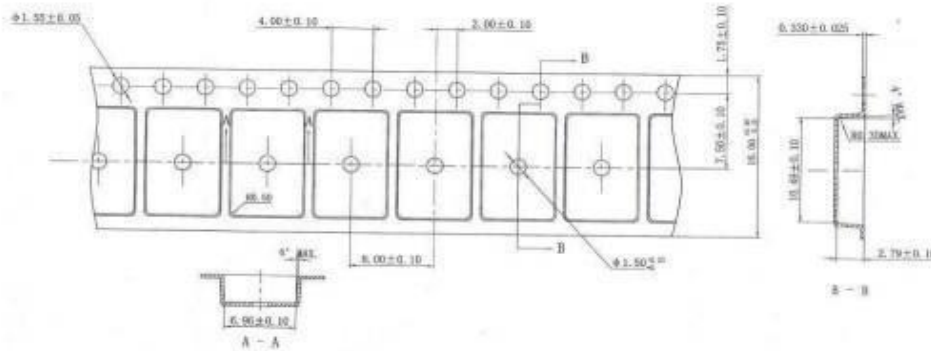



## 外形尺寸 PACKAGE MECHANICAL DATA TO-251

单位 Unit : mm

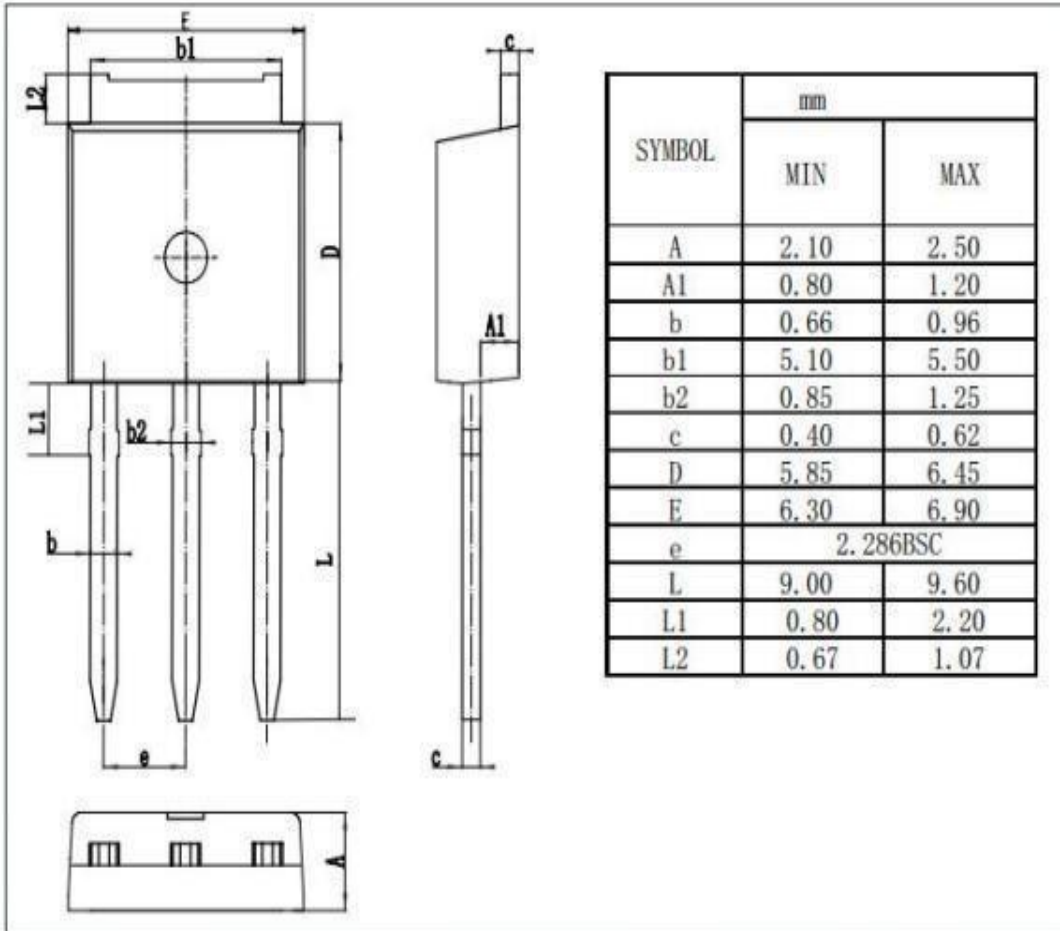



## 注意事项

1. 深圳市华天微电子有限公司的产品销售分为直销和销售代理，无论哪种方式，订货时请与公司核实。
2. 购买时请认清公司商标，如有疑问请与公司本部联系。
3. 在电路设计时请不要超过器件的绝对最大额定值，否则会影响整机的可靠性。
4. 本说明书如有版本变更不另外告知

## NOTE

1. Shenzhen Huatianwei Electronics co., Ltd sales its product either through direct sales or sales agent , thus, for customers, when ordering , please check with our company.
2. We strongly recommend customers check carefully on the trademark when buying our product, if there is any question, please don't be hesitate to contact us.
3. Please do not exceed the absolute maximum ratings of the device when circuit designing.
4. Shenzhen Huatianwei Electronics co., Ltd reserves the right to make changes in this specification sheet and is subject to change without prior notice.

## 联系方式

深圳市华天微电子有限公司

公司地址：广东省深圳市龙华清湖硅谷动力清湖园A14栋3楼

电话：86-755-82047720

网址：[www.htwdz.com.cn](http://www.htwdz.com.cn)

邮箱：[grf@htwdz.com.cn](mailto:grf@htwdz.com.cn)

## CONTACT

SHENZHEN HUATIANWEI ELECTRONICS CO., LTD.

ADD: Floor 3, Building A14, Qinghu Power park, Qinghu Silicon Valley, Longhua, Shenzhen, China

TEL: 86-755-82047720

Web Site: [www.htwdz.com.cn](http://www.htwdz.com.cn)

邮箱：[grf@htwdz.com.cn](mailto:grf@htwdz.com.cn)